

## OPTICAL RESEARCH CHAMBER FOR STUDIES AT PRESSURES TO 100 kbar

N. S. Fateeva and L. F. Vereshchagin

UDC 539.89

A steel high-pressure chamber for optical studies built to take pressures to 100 kbar is described. The reproducibility of the results in repeated use at the maximum pressure is  $\pm 6\%$ .

Chambers of different designs are employed in investigations of the physical properties of different materials at high pressures, with pressures brought about by means of one, two, three, or even six plungers [1-4]. A typical feature common to all these designs is the fact that, for work at pressures upwards of 30 kbar, the working part of the chamber and the plungers are made of cermet hard alloys, with a tungsten carbide base and steel outer support.

We decided upon a cylindrical chamber provided with two plungers as the most suitable variant for optical research in the range of high pressures and high temperatures. The initial variant of such a chamber, designed for research at pressures to 40 kbar [5], was made in its entirety of different grades of structural steel. The facility comprised a system of two coaxially nested cylinders fitted into each other with an interior cylindrical hole serving as the chamber effective space. The chamber is equipped with two steel cylindrically-shaped plungers, one of which, free to move, serves to generate the required pressure, while the other, insulated from the chamber walls, is immobile and serves as lead-in for the electric current to heat the test specimen. The insulation for this plunger is mica bonded to the plunger walls by a bakelite varnish. The supports for the chamber and plungers are made of ductile steel of moderate hardness. Crystalline NaCl serves to transmit the pressure, as a transparent medium. The holes in the chamber walls functioning as ports for determining the temperature of the test specimen from the radiation emitted by the specimen are also made of crystalline NaCl. The melting curve of graphite was measured on this facility by an optical method.

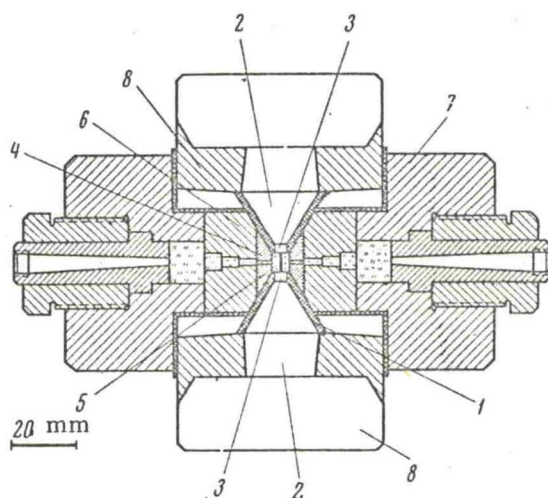

Fig. 1. Chamber for optical studies, built to take pressures of 100 kbar.

The two plungers were both made mobile in order to facilitate research in the more extended range of high pressures, and in order to enhance the mechanical strength of the cone configuration [6]. The insulation and sealing of the plungers was taken care of by means of a thin layer of fluorocarbon. In order to minimize deformation of the working part of the vessel, which would inevitably be manifested in that design in the form of a bulging of the chamber effective volume, the chamber was made as a composite structure, with the interior (lining insert) fitted into the exterior portion by a taper fit. It was not possible to raise the pressures above 60 kbar in a chamber of that design, because of excessive leakage of salt into the clearance between the plunger and the vessel wall, on account of the high fluidity of the fluorocarbon sealant.

In a new design of the facility, shown in Fig. 1, the fluorocarbon was replaced by talc 1, and the

Institute of High-Pressure Physics, Academy of Sciences of the USSR. Translated from *Pribory i Tekhnika Eksperimenta*, No. 3, pp. 222-224, May-June, 1970. Original article submitted September 24, 1969.

©1970 Consultants Bureau, a division of Plenum Publishing Corporation, 227 West 17th Street, New York, N. Y. 10011. All rights reserved. This article cannot be reproduced for any purpose whatsoever without permission of the publisher. A copy of this article is available from the publisher for \$15.00.

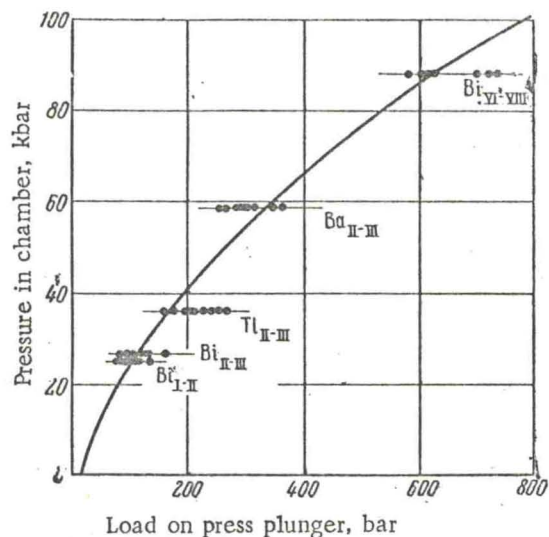

Fig. 2. Calibration curve in pressures, for chamber built to take 100 kbar.

The chamber 6 depicted in Fig. 1 was made of U-8 grade steel, tempered to Rc = 48 to 50. The liner 4 was made of U-10 grade steel, tempered to Rc = 60 to 62. The plungers were made of U-10 grade steel, tempered to Rc = 58 to 60. The outer support 7 of the chamber 6, as well as the supports of the pistons 8, were made of 45KhNMFA steel, with subsequent tempering to Rc = 45 to 48.

As the investigations showed, the chamber is capable of withstanding pressures to 100 kbar, and can be used repeatedly, with no changes of any consequence in the accuracy of the pressure measurements.

Pressure calibration of the chamber, i.e., correlation of the pressures within the chamber to the loads on the press plunger, was carried out in terms of the polymorphic transitions in Bi, Tl, and Ba, corresponding to 25.4, 27.0, 36.7, 59.6, and 89.0 kbar. Results of the calibrations (Fig. 2) as processed by the method of least squares showed that the rms error in pressure measurements did not exceed  $\pm 6\%$  up to pressures of 100 kbar. All of the chambers are intended for optical investigations, and were provided with side cylindrical viewing ports, steps widening out from the center to the periphery  $\phi$  0.8, 1.5, 3.0, 5.0, and 12.0 mm at the respective heights 4.5, 5.0, 5.0, 5.0, 5.0, and 10 mm. The ports were filled with crystalline NaCl. This chamber, like its precursors, can be used for investigations of other processes occurring at high pressures and high temperatures.

The participation of G. V. Shcheglakov and M. N. Vostrikov in the work is gratefully acknowledged.

#### LITERATURE CITED

1. R. A. Fitch, T. E. Slykhouse, and H. G. Drickamer, *J. Opt. Soc. America*, **47**, No. 11, 1015 (1957).
2. H. T. Hall, *Rev. Sci. Instrum.*, **29**, 267 (1958).
3. H. T. Hall, *Rev. Sci. Instrum.*, **31**, 125 (1960).
4. V. P. Butuzov, S. D. Mirinskii, and G. S. Kats, in: *Experimental Research in Depth Processes* [in Russian], Izd-vo AN SSSR (1962), p. 172
5. N. S. Fateeva, L. F. Vereshchagin, and V. S. Kototygin, *Dokl. Akad. Nauk SSSR*, **152**, No. 2, 317 (1963).
6. L. F. Vereshchagin and N. S. Fateeva, *Zh. Éksp. Teor. Fiz.*, **55**, No. 4, 1145 (1968).